

THE INTERMEDIATE VFO

Some Intermediate tutors have reported difficulties in either obtaining parts for the RSGB Intermediate textbook VFO or in getting the VFO going once they have the parts. This alternative design, based on the VFO in Ashar Farhan's BITX transceiver, has been adapted for use on the 80m band. It has been tried and tested and works very well using easy to find parts.

Circuit

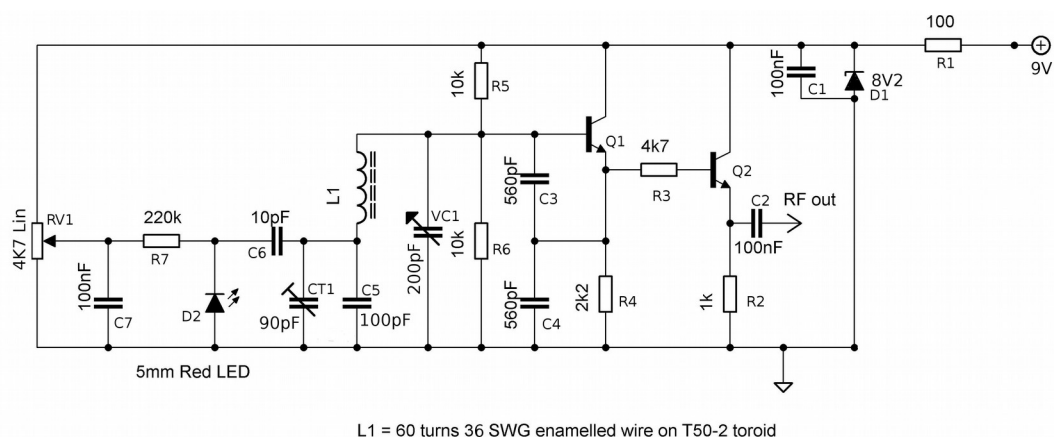

L1 = 60 turns 36 SWG enamelled wire on T50-2 toroid

The circuit is a fairly standard Colpits VFO, although the series tuning is sometimes credited to Gouriet-Clapp. It uses an NPN bipolar transistor in place of the more usual FET to maintain oscillation. Several versions have been built with different transistors, including some unmarked surplus transistors of Russian origin and all have worked well; this circuit does not seem to be too fussy about which NPN transistor you use.

Another NPN transistor acts as a buffer amplifier to allow the VFO to be used in a number of radio projects.

The inductor in the tuned circuit is wound on a T-50-2 toroid. Whilst this does not really allow much variation in the inductance, other than by stretching/squeezing the turns, the toroids are easier to find than the TOKO KANK inductors used in the original design.

The main tuning variable capacitor should be around 220pF maximum for full band coverage. However, a smaller value capacitor can also be made to work (see later).

The circuit also includes a fine tune feature, which is extremely useful on the air. The use of a light emitting diode acting as a variable capacitance diode may raise some eyebrows, but it works well and LEDs are more readily available than vari-caps.

The fine tune components (the 10pF capacitor and everything to the left of it in the circuit diagram above) can be omitted if the VFO use is going to be limited to Intermediate calibration exercises. A PCB is supplied since this gives a person new to construction the best chance of ending up with a working project!

Parts List

R1	100Ω
R2	1kΩ
R3	4.7kΩ
R4	2.2kΩ
R5, R6	10kΩ
R7	220kΩ
RV1	4.7kΩ linear
C1, C2, C7	100nF (marked 104)
C3, C4	560pF (marked 561)
C5	100pF (marked 101)
C6	10pF (marked 10 or 100)
CT1	90pF trimmer
VC1	220pF variable capacitor
Q1, Q2	BC547 (or any similar NPN)
L1	T-50-2 Inductor Core (red toroid)
D1	8V2 Zener diode
D2	5mm LED

1200mm of 36swg enamel copper wire

4 Small self-adhesive rubber feet

Large pointer knob for main tuning capacitor

Smaller pointer knob for fine-tuning pot

Hook up wire

PP3 Battery Clip

Tools

Soldering Iron & solder

Small flat bladed screwdriver

Side cutters

Wire stripper

Craft Knife

1.5mm Allen key (to fix the pointer knob)

Flat fine file or Emery paper

Construction

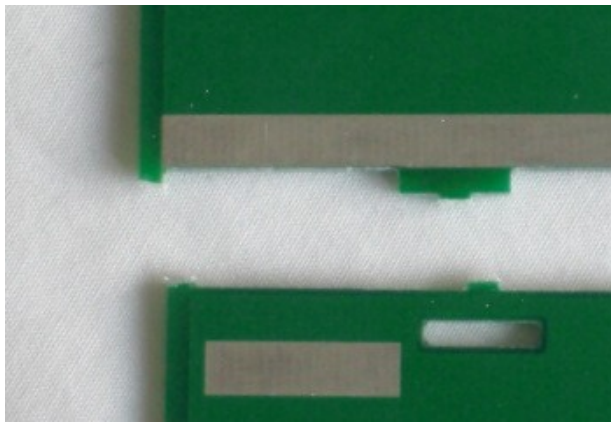

Start by preparing the PCB. Using a sharp craft knife or a pair of side-cutters separate the two halves.

Using a fine flat file or emery paper clean up the edges of the PCB.

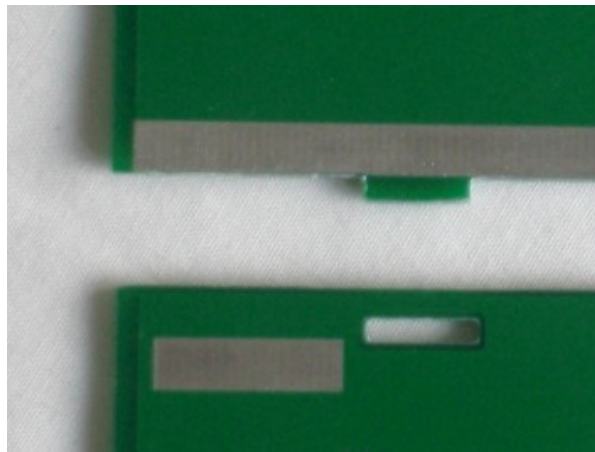

Place the tabs in the slots and with the two halves of the board held at 90 degrees to each other solder them together along the three pads.

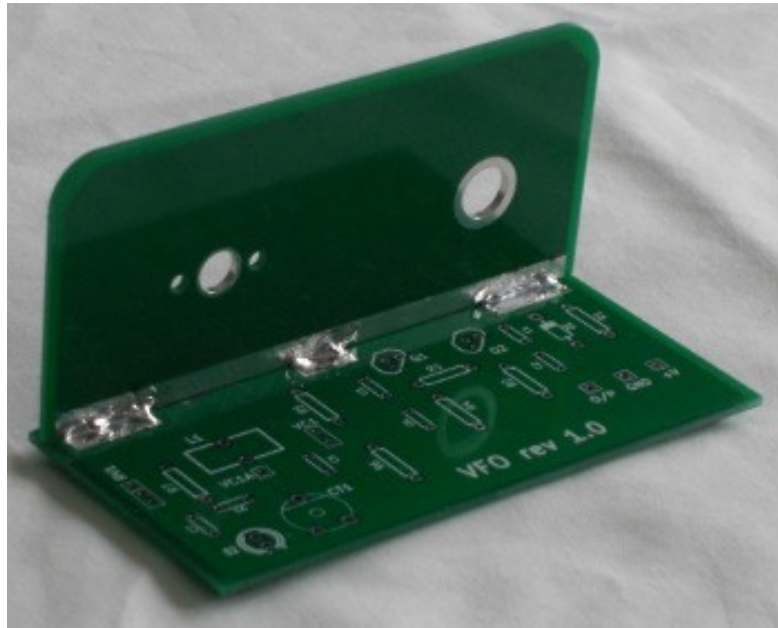

Next stick the 4 rubber feet to the underside of the baseboard.

The order of build is not critical for this little project. However, it *is* important to keep component leads as short as possible. The resistors should be flat to the PCB and the remaining components should not be more than a few millimetres above the PCB surface.

Fitting R1, C1, D1 (observing the polarity) and the battery clip first allows the V+ rail to be easily checked.

Next fit R2, R3, R4, R5, R6 and C2, C3, C4, C5 and CT1.

Then fit Q1 and Q2 being careful to get them the correct way round. The outline on the PCB was incorrect and has been corrected in ink.

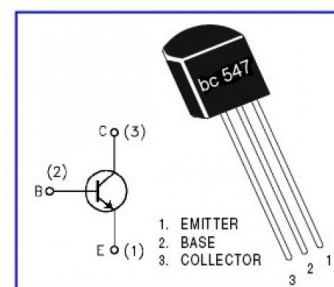

Bolt the Polyvaricon to the front panel with the leads downwards, the centre lead should be bent back against the panel and soldered to the earth pad. The other two leads should be at 45 degrees to the panel. Strip about 2.5cm of the insulation from the end of a hookup wire and use it to bridge the two outer connections cut the wire leaving sufficient to reach the VC1 pad on the PCB.

Prepare the inductor (L1) by winding 60 turns of 36swg wire onto the T-50-2 toroid. Each time you pass the wire through the core counts as one turn. Spread the turns evenly around the toroid leaving 2 'tails' about 20mm long.

Using the blade of a craft knife, or some abrasive paper, scrape the enamel off the tails to within a few millimetres of the inductor core. If you are not sure whether you have got all the enamel off, test for continuity using your ohmmeter set to the lowest ohms range. If you are touching bare copper on both tails you will get a very low resistance reading. If you get a high reading you need to scrape off some more enamel.

Solder the Inductor in place and secure it with a blob of 'hot-glue' or melted candle wax. If you want to demonstrate how non-rigid construction can affect frequency stability, then don't secure the inductor!

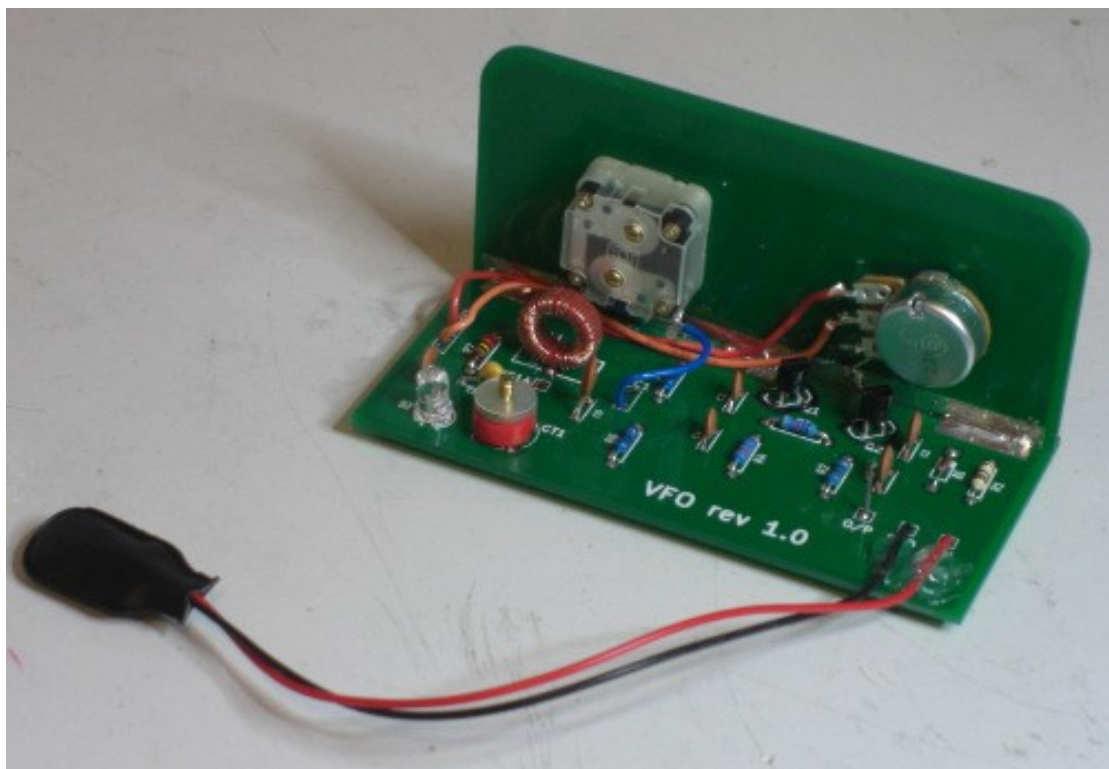

The basic VFO is now complete and ready for testing. Below is a view of the completed board (including the Fine tune section). It is easier to test if a short scrap piece of component lead is soldered to the O/P connection to act as a terminal pin. Now comes the moment of truth - does it work? Connect up a 9 volt battery and check that the VFO is generating an RF signal:

- **Use an RF probe.** An RF probe is one of the most basic, but useful, pieces of test equipment you are ever likely to own. Connect the leads of the RF probe between the point marked 'O/P' and ground (the baseboard) and set the multi-meter to read DC volts. A high range should be used first to get some idea of what you are measuring. In this case, you should expect something like 2 or 3 volts (peak-to-peak).
- **Use an oscilloscope.** If you have a scope then by all means use it. Connect the leads of the probe between the point marked 'O/P' and ground (the baseboard) and set the Y-axis to read something like 1V per division. You should expect something like 2 or 3 volts (peak-to-peak).
- Once you have confirmed that the oscillator is working we need to check that it is oscillating on the frequency we want it to – a key requirement for any oscillator! If you have an oscilloscope and it is up to it, you might be able to read off the time period and work out the frequency. If not, read on.
- **Connect a frequency meter across the output.** Do not panic if you do not have one, please read on. A frequency meter displays the frequency of any signal that is applied to its input, so long as it is strong enough to register and not so strong as to overload it. Some multi-meters have this facility built in. If you have access to a frequency meter, or a multi-meter with this facility, then use it now. Connect the meter leads between the point marked 'O/P' and ground (the baseboard). You should find that the oscillator output is somewhere around 3 or 4MHz. If you don't have a frequency meter, try the next test.
- **Listen for the oscillator on a receiver.** If you have a receiver covering the 3.5MHz band tune it to 3.650MHz and set it to receive CW, USB or LSB mode. Connect a length of wire to the receiver antenna socket and place the other end near the VFO. Now tune the VFO across its range by moving the variable

capacitor across its range. You should be able to hear the VFO output at some point. When you find it, just touch part of the circuit and you should hear a slight change in the oscillation. This confirms that you are receiving the oscillator and not some other signal.

Once you have confirmed that your oscillator is working correctly, you need to ensure that its range can be adjusted to include the 80m band.

Use your frequency checking equipment (frequency meter or receiver) to find the frequency at each end of the VFO's range. If you are really lucky the VFO will be oscillating between 3.500 and 3.850MHz. If you are less fortunate, set the VFO to its lowest frequency and adjust the 90pF trimmer until you have 3.500MHz, and check the range again. You may find that you cannot cover the full range of frequencies. This depends on the variable capacitor you are using. For the Intermediate calibration exercise one band edge and a number of calibration points will suffice.

Advice Note - If you are using a smaller value variable capacitor it will not give the range required by connecting it as shown in the layout. However, if you connect it to the junction of the inductor and the 90pF trimmer it can be made to do the job. The 60pF section of a polycon connected using a 270pF capacitor worked very well. A 25pF maximum variable would probably not need the series capacitor – experiment with what you have!

Finally, if you wish, fit the parts for the fine tune control C6, C7, R7, D2 and RV1. Note that D2 (the LED) is being used as a vari-cap diode and so is fitted *backwards* with the anode (the longer lead) connected to ground (the pad nearest the edge of the PCB).

The pot should shift the VFO a few kHz either side of the set frequency as you move it away from the mid point of its travel. Note that for the calibration exercise it should be set to the mid point and **not** used to calibrate the VFO. As stated above, if the VFO is merely going to be used for Intermediate calibration exercises, the fine-tuning pot is probably best left out.

Thanks go to Steve Hartley, G0FUW for the improved circuit design and to The Cambridge & District Amateur Radio Club (CDARC) who backed the project.

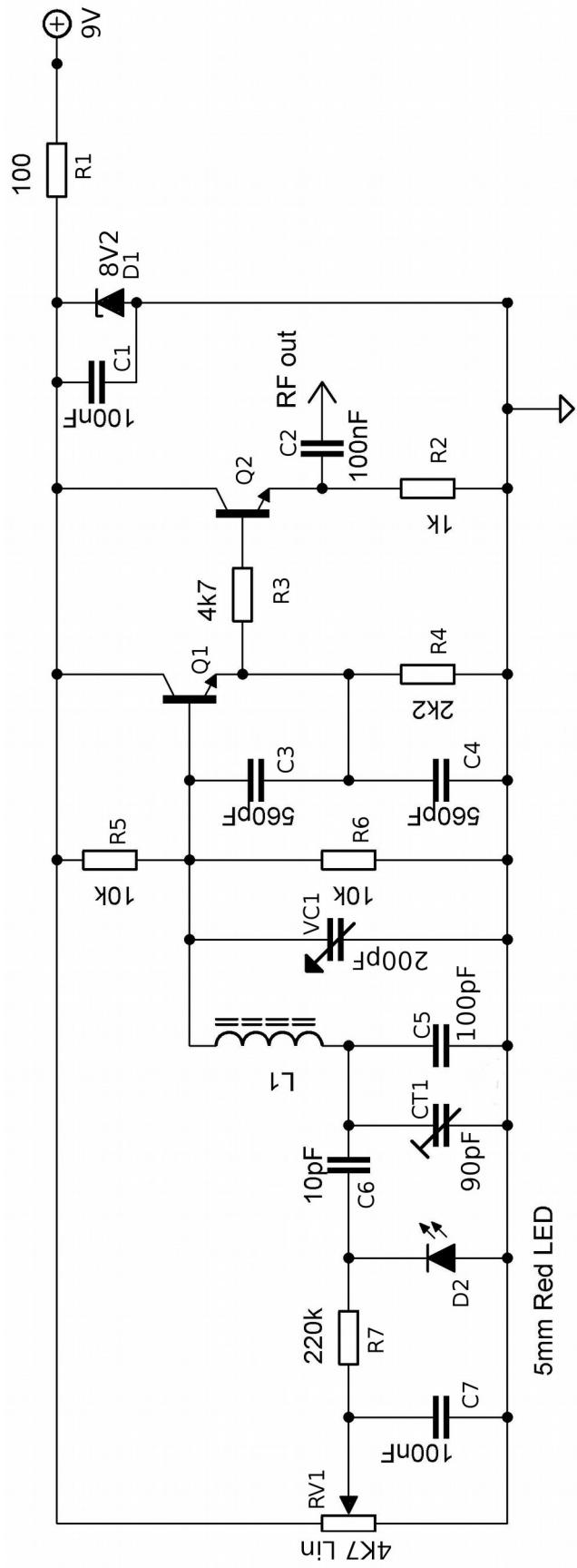

L1 = 60 turns 36 SWG enamelled wire on T50-2 toroid